

Automatic Switchover Gas Chlorination Systems Series 9000 Instruction Manual

All ENCHLOR Chlorination systems are carefully designed and tested for years of safe, accurate field service. All ENCHLOR Chlorination systems are chlorine tested, at customer specified conditions, prior to shipment. All ENCHLOR products are made of the finest materials. To insure best operation, read these instructions carefully and completely and store them where all maintenance personnel will have access to them.

Each 9000 Series gas chlorination system consists of the following:

1. The vacuum regulators which mount on the chlorine cylinders.
2. A wall mounted flow meter with manual control valve.
3. The ejector, with nozzle and diffuser, mounts directly to the pipe line, tank, wet well, or to a solution line.
4. Standard accessories:
 - a. Appropriate polyethylene tubing for vacuum lines.
 - b. Ten lead gaskets for each vacuum regulator.
5. Additional parts available from any plumbing supply, or can be ordered through Enchlor.
 - a. Pressure gauge.
 - b. Water shut off valve.
 - c. Y-type strainer.

Gas Chlorination Systems
Series 9000
Operation & Maintenance Manual

Table of Contents

I.	SAFETY INFORMATION	3
II.	DESIGN AND INSTALLATION NOTES	3
III.	SYSTEM INSTALLATION	4
	1. Installation of Enchlor Inc. Ejector	4
	2. Installation of Enchlor Inc. Vacuum Regulator	5
	3. Connecting Vacuum Lines	5
	4. Remote Meters	6
IV.	CHLORINATION SYSTEM VACUUM TEST	6
V.	START UP OF CHLORINATION	7
VI.	SHUT DOWN PROCEDURE	7
VII.	CHANGING CYLINDERS	7
VIII.	RATE VALVE OPERATION	8
IX.	TROUBLESHOOTING	8
	1. Pressurized Leaks	8
	2. No Chlorine Feed	9
 APPENDIX: SERVICING THE ENCHLOR INC. SYSTEM		
A-1.	VACUUM REGULATOR	9
A-2.	INLET ASSEMBLY	9
A-3.	REMOTE METER	10
	1. Cleaning the Rate Valve	10
	2. Cleaning the Meter Tube	10
A-4.	EJECTOR/CHECK VALVE ASSEMBLY	11
	1. Loss of Vacuum at the Ejector	11
	2. Servicing the Ejector Check Valve Assembly	11
 DRAWINGS		
	1. Vacuum Regulators	12-13
	2. Ejectors	14-16
	3. Remote Meters	17-19
 NOZZLE TABLES		
		20-21

SECTION I: SAFETY INFORMATION

TAKE CARE WITH CHLORINE!

1. Always keep chlorine cylinders in an upright position with the valve cap screwed on tight before moving full or empty cylinders. Cylinders should be moved with care.
2. A safety chain must be placed around the cylinder and secured to a wall. Spare full cylinders should also be secured carefully.
3. For best operation and safety, the vacuum regulator and cylinders should be protected from the elements including direct sunlight.
4. Never place heaters or heat lamps directly on a cylinder.
5. Ammonia gas should NOT be stored or fed in the same room with chlorine. Contact of the gases may result in an explosive mixture.

IMPORTANT NOTE:

Take extreme caution when using chlorine gas manifolds. Manifolds contain pressurized chlorine gas there- by increasing the risk of a pressurized chlorine leak. Enchlor vacuum regulators are designed to mount directly onto the valve of chlorine and sulfur dioxide cylinders. Direct cylinder mounting is the easiest and safest configuration to operate and maintain. With this configuration, the chlorine gas flows under vacuum everywhere beyond the one pressure point at the chlorine cylinder valve.

SECTION II: DESIGN AND INSTALLATION NOTES

1. The “all vacuum” system means that system will shut off at the cylinder valve, should the vacuum line be broken, if water is stopped for any reason, or if the chlorination equipment is physically damaged.
2. Choosing the right feed rate capacity:

VACUUM REGULATOR SHOULD BE ON MAXIMUM POSSIBLE FLOW.

Imperial Units:

$$\text{GPM} \times 0.012 \times (\text{PPM}) \text{ Dosage} = \text{PPD}$$

Gallons Per Minute Parts Per Million Pounds Per Day (Cl 2)

Example: $600 \text{ GPM} \times 0.012 \times 3 \text{ PPM} = 21.6 \text{ PPD}$

In this example a 50 PPD system would be appropriate.

Metric Units:

$$\text{LPM} \times 0.0599 \times (\text{PPM}) \text{ Dosage} = \text{GPH}$$

Liters Per Minute Parts Per Million Grams Per Hour (Cl 2)

3. TOTAL BACK PRESSURE is the pressure in the pipeline to be chlorinated plus the friction losses in the solution line between the ejector and the point of injection at the pipeline. Ejectors capable of operating with backpressures up to 140 Psig are standard. For higher backpressure consult factory.
4. It is preferable to locate the ejector at the point of solution injection in order to eliminate the need for solution lines. Friction losses in the solution line will increase the ejector backpressure. To reduce the friction losses, increase the solution line internal diameter and limit the number of flow restrictions and turns. Also be sure that the solution line material is resistant to the highly concentrated chlorine

mixture. Avoid solution lines wherever possible.

5. The chlorine gas is carried from the vacuum regulator to the ejector through the specified black polyethylene tubing. Up to 100 feet of polyethylene tubing between vacuum regulator and ejector is standard. For longer distances consult factory.

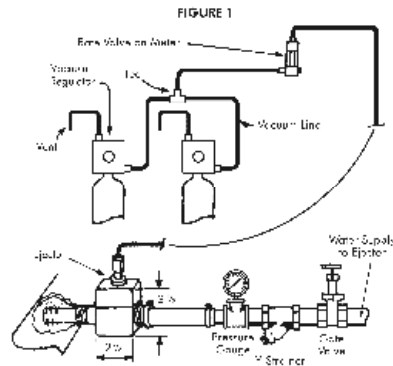

A typical installation injecting chlorine into a pipe line using city water.

(I) INSTALLATION OF EJECTOR (Refer to Figures 1 and 2)

1. Installation of EJECTOR:

- Remove the diffuser from the ejector assembly and place 2 wraps of Teflon tape on diffuser threads.
- Do Not install diffuser into pipe line when assembled with ejector.
- Turn diffuser by hand into NPT threads of pipe line (3/4" or 1 1/4" NPT). Place wrench on diffuser and tighten one half turn maximum.
- Reconnect diffuser to ejector making sure appropriate O-rings are on each side of nozzle and diffuser.

2. Testing of ejector. (Note: The vacuum regulator should still be in the shipping case.)

- Piping hook up to ejector (Refer to Figures 1 and 2 and Servicing Section in this Manual).
 - Ejector should be installed down stream at a sufficient distance so that chlorinated water is not re-circulated through the booster pump. (See Figure 2.)
 - On the water inlet side to the ejector nozzle the following should be installed: a gate valve, Y-strainer, and a pressure gauge.
- Testing for sufficient pump pressure to operate ejector. Also checking that booster pump (if applicable) operating in the proper direction. Refer to ejector performance charts and tables at end of this manual.

Note 1: Ejector must have some back pressure to prevent jetting. (Jetting causes loss of vacuum)

Note 2: When chlorinating into a contact chamber a tee should be installed on the solution line with a vacuum breaker to prevent siphoning.

- If operating with city water pressure (no booster pump), open the water inlet valve to the ejector and feel

for suction (with your finger) at the fitting on the top of the ejector.

- If pump is operating in proper direction there should be a strong vacuum at the fitting on the top of the ejector. Feel for suction (with your finger) at the fitting on the top of the ejector.

- If the ejector has tested satisfactorily continue on to the next step (Mounting the Vacuum Regulator).

SECTION III: SYSTEM INSTALLATION

(II) INSTALLATION OF VACUUM REGULATOR

NOTE: The chlorine cylinder valve is CLOSED. Do not open until instructed to do so.

1. See that safety chain is secured around chlorine cylinder.
2. Remove the cylinder protection cap from the chlorine cylinder.
3. Examine the vacuum regulator for obvious damage.
4. Remove masking tape used for shipping purposes.
5. Place lead gasket over vacuum regulator inlet assembly.
6. While placing lead gasket on vacuum regulator see that the filter has not fallen out of inlet assembly. (This filter is necessary to remove particles that will cause venting.) The filter should be inspected each time the cylinder is changed.
7. Mount vacuum regulator on cylinder valve being sure the yoke screw is backed out far enough for sufficient clearance. While tightening the yoke screw be certain that the lead gasket stays in place. Excessive tightening can damage gasket and/or yoke screw. DO NOT USE EXCESSIVE FORCE. See torque specifications below.

(III) CONNECTING VACUUM LINES BETWEEN VACUUM REGULATOR AND EJECTOR AND VACUUM

REGULATOR VENT TO OUTSIDE (Refer to Figures 1 and 2)

1. The side connector of vacuum regulator is for vacuum line tubing to ejector. (Allow enough vacuum tubing for changing cylinders.)
2. Connect vent tubing to second connector on the vacuum regulator and vent to safe area outside of building. (Place bug screen outside on end of vent tubing.)

NOTE: Do Not connect vent lines from two vacuum regulators to one common vent. You must run separate vent lines to the outside, when using multiple vacuum regulators.

(IV) REMOTE METERS (Refer to Figure 2)

1. Remote Meters: (Gas flow is from bottom to top through the tube)
 - a. Connect the line in to the bottom tube connector.
 - b. Connect the line out to the ejector to the top connector.

A Switchover System injecting chlorine into a pipeline using a turbine positive displacement pump.

Pressure relief valve must discharge to a drain or outside of building. Note the by-pass piping from pump discharge through by-pass valve back to suction side of pump.

NOTE: By-pass valve must never be completely closed.

NOTE: Pump suction and ejector must be from the side of the pipeline, not from the top of the line.

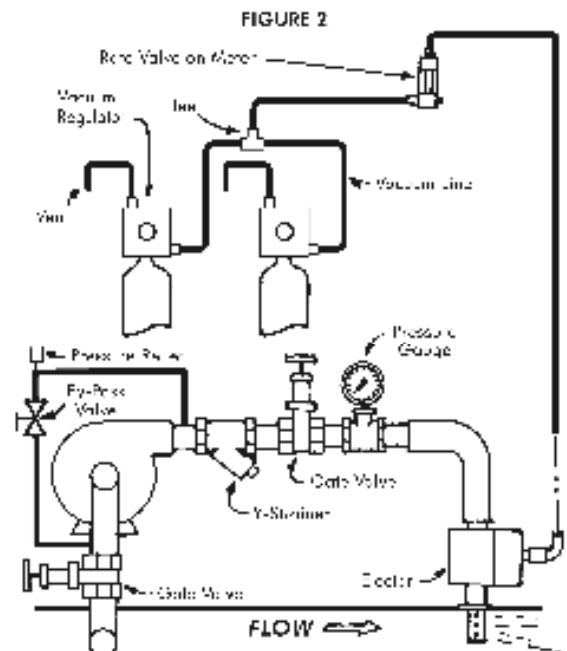

SECTION IV: CHLORINATION SYSTEM VACUUM TEST

1. Do Not open chlorine cylinder valve until vacuum test is satisfactorily completed.

a. Vacuum Test

With the chlorine cylinder still closed, start the ejector booster pump and the meter tube ball should drop to the bottom within about ten seconds. If the ball continues to bounce there is either a leak at the lead gasket or a loose connection at the vacuum tube fittings or meter tube. (The tube fittings should be hand tight. It is not necessary to use pliers or a wrench on these fittings. If meter tube needs tightening, use a quarter and finger tighten inlet plug.) At this time the rate valve on the vacuum regulator should be open two or three turns.

b. If the ejector is operating properly (pulling sufficient vacuum) then the front bolts should be depressed on both vacuum regulators.

c. Turn off water supply to ejector.

d. Wait 5 to 10 minutes with water supply off. The ball should remain still at the bottom of the meter tube.

e. If the system is vacuum tight proceed to the next step.

f. Disconnect vacuum tubing at the vacuum regulator to allow air to enter the system. Reconnect tubing.

g. Place one of the vacuum regulators in standby by turning the front knob two turns counter-clockwise and then returning it two turns clockwise. The front bolt should remain protruding per the diagram on the vacuum regulator.

SECTION V: START UP OF CHLORINATION

Material necessary: A small plastic squeeze bottle, 1/3 full of household ammonia, for detecting chlorine leaks. When ammonia fumes contact chlorine gas a visible smoky vapor is produced. (Wipe up any splashed liquid ammonia.)

1. Open chlorine cylinder valve 1/4 turn and close immediately.

2. Squeeze ammonia bottle at gasket and yoke assembly area: if no vapor appears the seals are tight and it is OK to proceed to the next step.

3. Open chlorine cylinder valve 1/4 turn, leave open, and recheck for chlorine leaks. (1/4 turn open of the cylinder valve is all that's required. The reason we specify 1/4 turn is that the valve can be closed with only 1/4 turn. In an emergency you can shut it off quickly and safely. The wrench stays on the cylinder valve while cylinder is open.)

4. Place one vacuum regulator in standby. This is done by turning the reset knob two turns counter-clockwise and then returning it two turns clockwise. The front bolt should remain protruding per the diagram on the vacuum regulator.

5. Turn on water supply or booster pump to ejector and set rate valve to desired flow rate. Read flow rate at center of ball on meter tube scale.

6. Rate valve is not a shut off valve: it is a flow rate control only. To shut off chlorine feed close the chlorine cylinder valve.

SECTION VI: SHUT DOWN PROCEDURE

1. Close both chlorine cylinder valves while pump is still running.
2. Wait for ball to rest at bottom of meter tube and the front bolt to be below the surface.
3. Break vacuum by removing the tubing at one of the vacuum regulators and reattach. (Repeat at least 2 times for more complete removal of gas from the system.)
4. Shut down the water supply to the ejector.

This procedure of shut down must be followed before a vacuum regulator is removed from a cylinder.

NOTE: After installing the vacuum regulator with a new lead gasket on a new cylinder, the vacuum tubing should be removed to allow air to enter the system and break the vacuum. Not releasing vacuum and turning on cylinder will slam the diaphragm forward and could cause damage to the diaphragm assembly. You can also accomplish breaking the vacuum by turning the rate valve out of the bonnet. Either way is acceptable.

SECTION VII: CHANGING CYLINDERS

When one cylinder is empty and the system has switched to feed from the other cylinder then the empty cylinder must be replaced and that vacuum regulator must be placed in standby mode.

1. Tightly close the valve of the empty chlorine cylinder. Follow all applicable guidelines in changing chlorine cylinders.
2. After replacing the empty with a full cylinder, inspect the vacuum regulator, the vacuum regulator filter and (using a new lead gasket) mount the vacuum regulator on the full cylinder.
3. Turn the front knob two turns counter-clockwise and then return two turns clockwise to place the vacuum regulator in standby. The front bolt should remain protruding per the diagram on the vacuum regulator.

SECTION VIII: RATE VALVE OPERATION

Turn the rate valve counter-clockwise to open it completely. Further turns will completely remove the rate valve from the flow meter tube, which will cause a loss of Cl₂ feed. (See Appendix for servicing instructions.)

The O-ring seals for the rate valve are locked in place under the valve bonnet and do not come out when the rate valve is pulled out of the bonnet.

PREVENTATIVE MAINTENANCE NOTE: Rate valves which are not exercised frequently may experience a build up of a white powdery substance which precipitates out of the chlorine gas. In order to avoid this build up, which can cause the rate valve to become stuck in place, it is recommended that the rate valve be periodically exercised. See Appendix for rate valve maintenance instructions.

SECTION IX: TROUBLESHOOTING

(I) PRESSURIZED LEAKS

1. Pressurized chlorine leaks are a safety hazard to life and equipment and should be corrected immediately. When searching for this type of leak there are basic safety rules to follow.
 - a. Air breathing pack should be readily available and personnel should know how to use it properly.
 - b. Exhaust fan switch should be located near outside entrance with alternate outside switch
 - c. Chlorine cylinder wrench should remain on the cylinder whenever cylinder is open.

- d. Plastic squeeze bottle 1/3 full of household ammonia.
- e. Buddy system used (two people capable of operating system).
- 2. If a leak is detected the following should be checked first:
 - a. The lead gasket between the chlorine cylinder valve and the vacuum regulator inlet assembly.
 - i. Tighten the half dog screw on the vacuum regulator yoke assembly which is used to secure the inlet assembly to the chlorine cylinder valve.
 - ii. Always use a new lead gasket.
 - b. Chlorine cylinder valve packing.
 - i. Tighten the cylinder valve with care, not excessively! Close the valve if problem persists and notify your chlorine supplier.
 - ii. If valve is the problem try to move cylinder with a high degree of safety to an outside location.
 - c. Chlorine leaking out the vent due to the inlet safety shut off valve having dirt on the valve seat.
 - i. Close the chlorine cylinder valves.
 - ii. Wait until the metering ball drops to zero on the flow tube.
 - iii. Turn off water supply to ejector.
 - iv. Now remove the leaking vacuum regulator from the cylinder valve.
 - v. See Appendix for inlet safety shut off valve servicing instructions.
 - vi. After servicing and remounting chlorinator with a new lead gasket, pull a vacuum test before you open the chlorine cylinder valve. See Section IV: "Chlorination System Vacuum Test".

(II) NO CHLORINE FEED

Possible causes:

- 1. No vacuum being produced by ejector.
 - a. Remove poly tubing from ejector fitting and place your finger on it; you should feel a strong suction.
 - b. If you feel no suction (vacuum) check in this order:
 - i. Nozzle (See Appendix): Turn off water supply and remove nozzle from ejector.
 - (1) It may be clogged or damaged by a stone or other foreign matter. Flush out or run pipe cleaner through carefully.
 - (2) If there is a build-up of rust, iron, or manganese, place the nozzle in a Muriatic acid for five minutes and rinse with water. If you see a black syrup substance you may find it necessary to clean the nozzle on a preventative maintenance schedule.
 - ii. Inlet Water Supply. Check that it is sufficient. Refer to nozzle curves in back of manual.
 - iii. Reduced city water pressure.
 - iv. Y strainer needs cleaning.
 - v. Booster pump cavitating (lost its prime).
 - vi. Booster pump insufficient boost due to wear or single phasing due to loss of one leg of power.
 - vii. Booster pump may have flooded suction.
- 2. Chlorine flow blocked at vacuum regulator inlet assembly.
 - a. The Inlet filter could be clogged.
- 3. Out of Chlorine.
 - a. The scale would read 150 lbs. lighter than when cylinder was new.
 - b. Meter tube ball would be at zero.

APPENDIX A – SERVICING THE SYSTEM

SECTION A-1: VACUUM REGULATOR

1. Follow the usual shut-down procedure carefully before removing any vacuum regulator from the gas bottle.
2. Make certain that the switchover mechanism indicated the regulator is in the “IN USE” position.
3. Using a 5/32" Allen-wrench, remove the socket head cap screw (BTE-511-500) and Kynar washers
4. Unscrew the reset knob (VRE-541-500) from the front body.
5. Remove the two yoke screws (BTE-STA-125) and pull the yoke assembly out of the vacuum regulator back body.
6. Unscrew the body bolts (BTE-STA-129 & BTE-STA-124) from the back body and pull the back body away from the front body until they separate.
7. Using a pair of pliers, and being careful to only grip the smooth portion of the shaft, remove the guide pin (VRE- 546-500) from the diaphragm assembly by turning clockwise.
8. To disassemble the diaphragm, grasp the front and rear plates and turn them apart (they are threaded together with normal, right-hand thread and may require the aid of a vice to disassemble).
9. Inspect all O-rings and replace if necessary.
10. Replace the guide pin (VRE-546-500).
11. After inspection and replacement of all necessary parts, reassemble the unit in reverse order.

SECTION A-2: INLET ASSEMBLY

WARNING: If the vacuum regulator leaks gas out the vent or any other place on the body the problem is most likely caused inside the yoke assembly. It is recommended that the yoke assembly be disassembled by a person experienced in Chlorine Vacuum Regulator maintenance because if it is not done properly dangerous leakage of pressurized gas could result.

1. Remove the inlet assembly from the yoke plate by slipping off the PVC retainer clip (VRH-142-500) that holds it to the yoke.
2. Remove the inlet filter material from the inlet capsule (VRH-141-501).
3. Disassemble the inlet assembly using a small flat-head screwdriver to hold the inlet valve (VRH-112-500) and a pair of pliers (and a protective cloth) to grip the vent plug (VRH-111-500) to unscrew these two parts. Take care as this assembly is under spring tension and small parts may be difficult to find if dropped.
4. Unscrew the seal plug (VRE-182-500) from the inlet capsule.
5. Remove the valve seat (VRE-110-500) from the inlet capsule by simply pushing the exposed threaded portion up through the inlet capsule. Note that the O-ring ORE-VIT-011 is attached to this seat.
6. Clean the inlet capsule, inlet spring (SPE-104-100) and inlet valve using a soft cloth or plastic cleaning pad. Do not use steel wool or other metal cleaning sponges on the inlet valve.
7. Using all new O-rings and new parts as needed, reassemble in reverse order.

SECTION A-3: REMOTE METER

(I) CLEANING THE RATE VALVE

1. Unscrew the rate valve knob and stem (by hand) completely out of the top meter block.
2. In low capacity systems (10 PPD or below) check to see if the point of the valve stem is broken or bent. If it is damaged it must be replaced.
3. Replace O-Rings on the rate valve stem.
4. Lubricate the new O-Rings lightly with Flourolube grease before replacing the rate valve and knob into the top meter block.

(II) CLEANING THE METER TUBE

1. While holding the glass meter tube (to prevent it from falling) unscrew the inlet plug at the base of the bottom meter block, until the meter tube can be removed.
2. Remember to be careful not to lose the stops or ball in the following steps.
3. Remove the white stops at either end of the tube (you could use a paper clip).
4. Soak the tube in warm water with a cleaner like lime away or Muriatic Acid. Also, brush the inside of the tube with a pipe cleaner.

NOTE: Always follow safety precautions with Muriatic Acid and other chemicals.

5. Dry the meter tube and reinstall the ball and stops.
6. It is recommended that new meter tube gaskets be used when reinstalling the meter tube.
7. Remove the inlet plug completely and inspect the O-Rings. If it has been more than 12 months since they were changed or if there is any noticeable damage, the O-Rings should be replaced.
8. Reinstall the inlet plug, meter gaskets and meter tube, making sure to center the tube on the top and bottom meter gaskets.
9. Tighten the inlet plug with reasonable force to make a seal. Do not use excessive force.

SECTION A-4: EJECTOR/CHECK VALVE ASSEMBLY

(I) LOSS OF VACUUM AT THE EJECTOR: If vacuum is lost at the ejector and water supply is sufficient, then the nozzle is most likely clogged, broken or loose. Before working on the ejector it must first be isolated so that water will not leak when the ejector is removed.

1. First detach the intake side (nozzle) of the ejector from the pipe line.
2. For 3/4" line size ejectors rotate the complete ejector body counter clockwise. This loosens the threaded portion of the nozzle from the diffuser. It also eliminates the need for pliers on the nozzle which could damage the plastic. For 1 1/4" line size ejectors remove the two flanges to remove the ejector.
3. Inspect the nozzle for:
 - Pipe scale, stones, dirt, etc...
 - Build-up of iron, manganese, calcium, etc...
4. The nozzle should be soaked and brushed with warm water mixed with a cleaner like Muriatic Acid.

NOTE: TAKE CARE NOT TO SCRATCH OR ATTEMPT TO MODIFY THE ORIFICE IN ANY WAY.

5. Using two new ORE-BUN-121 O-rings the ejector can now be reassembled.

When reassembling 3/4" line size ejectors the nozzle and diffuser should be screwed together hand tight leaving the ejector body 90 degrees to the left of its final position. Once the nozzle and diffuser are hand tight, the ejector can then be turned the final 90 degrees.

WARNING: Do not use excessive force in tightening the nozzle, diffuser and ejector assembly. The ejector is constructed of PVC and excessive force can break the parts.

(II) SERVICING THE EJECTOR CHECK VALVE ASSEMBLY: If water leaks back into the system, this means that the ejector check valve has failed. This could be caused by incorrect assembly, a failed

gasket, O-Ring or diaphragm, or foreign material lodged in the check valve.

1. Remove the four bolts holding the ejector body together.
2. Inside you will find a diaphragm assembly and a spring.
3. The diaphragm assembly can usually be unscrewed by hand. If it is too tight, carefully try large jaw pliers or a vice. Note that a plastic support diaphragm is on the top side of the rubber diaphragm. The purpose is to protect the softer rubber diaphragm in installations with high pressure.
4. Inspect the rubber diaphragm for holes or weak points.
5. Inspect the ORE-CEM-210 O-Ring. Replace if damaged.
6. Reassemble the diaphragm assembly, preferably with a new rubber diaphragm, DIE-104-500.
7. Install the assembly in the recess between the ejector body halves being careful to install the spring properly below the assembly.

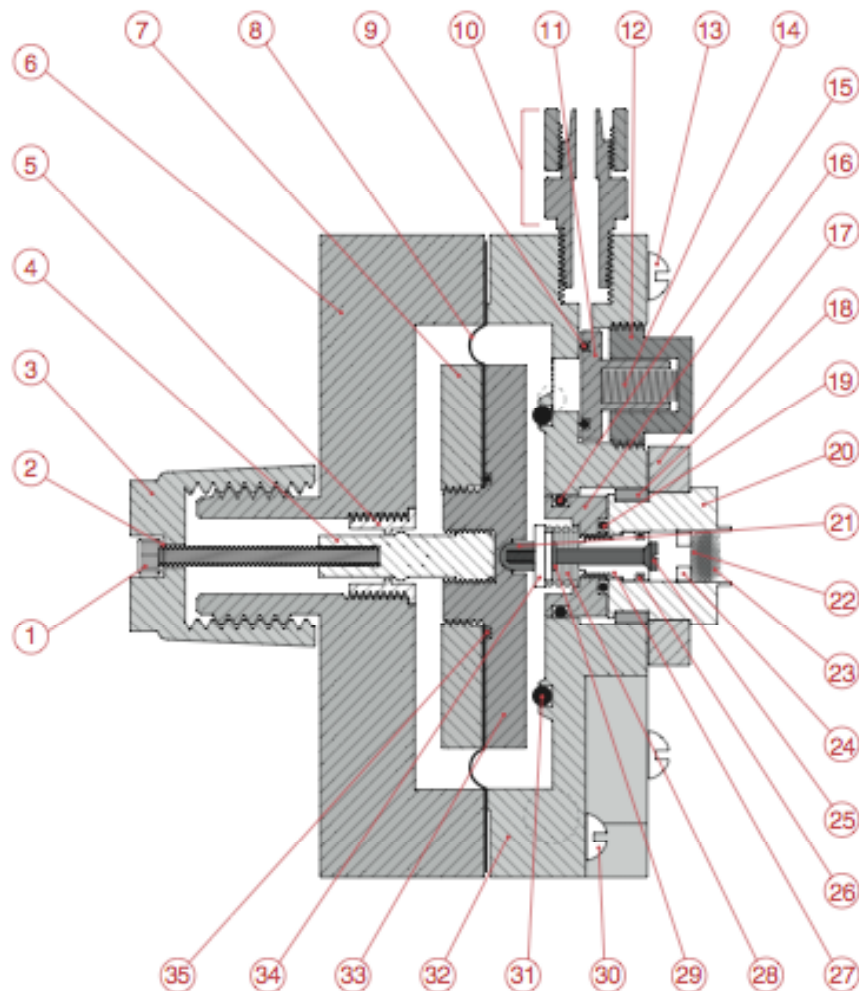

Item No.	Part No.	Description	Qty.	Item No.	Part No.	Description	Qty.
1	BTE-STA-511	10-24 x 2" Socket Head Cap Screw	1	24	YRE-184-500	Filter Stop	1
2		Kynar Washer	1	25	YRE-112-500	Inlet Valve	1
3	YRE-541-500	Vacuum Reset Knob	1	26	ORE-YIT-011	O-Ring	1
4	YRE-546-500	Guide Pin	1	27	YRE-110-500	Valve Seat	1
5	YRE-545-500	Collar	1	28	SPE-104-000	Inlet Spring	1
6	YRE-555-500	Front Body	1	29	YRE-113-500	Spring Holder	1
7	YRE-269-500	Diaphragm Front Plate	1	30	BTE-STA-124	1/4 - 20 x 1 3/4" Bolt	1
8	DIE-106-500	Diaphragm	2	31	ORE-YIT-332	O-Ring	1
9	ORE-CEM-114	O-Ring (Vent Valve)	1	32	YRE-556-250	Back Body (up to 250 PPD)	1
10	TCE-100-100	Vent Tubing Connector (3/8")	1	32	YRE-556-500	Back Body (500 PPD)	1
11	YRE-521-500	Vent Cup	1	33	YRE-547-500	Diaphragm Back Plate	1
12	YRE-522-500	Vent Cap	1	34	YRE-183-500	Spring Retainer	1
13	BTE-STA-129	1/4 - 20 x 2 1/4" Bolt	4	35	ORE-YIT-028	O-Ring	1
14	SPE-100-000	Vent Spring	1	*	BTE-STA-125	1/4 - 20 x 2 3/4" Bolt	2
15	ORE-YIT-212	O-Ring	1	*	TCE-100-100	3/8" Tubing Connector (100 PPD)	1
16	YRE-182-500	Seal Plug	1	*	TCE-106-250	1/2" Tubing Connector (250 PPD)	1
17	YRE-346-500	Yoke Assembly	1	*	TCE-110-500	5/8" Tubing Connector (500 PPD)	1
18	YRE-142-500	Retainer Clip	1				
19	ORE-YIT-112	O-Ring	1				
20	YRE-141-501	Inlet Capsule	1				
21	YRE-111-500	Vent Plug	1				
22	YRE-101-500	Inlet Screen	1				
23	YRE-455-500	Filter Floss	1				
				* - Not shown. Series 9000 Vacuum Regulator Cylinder Mounted			

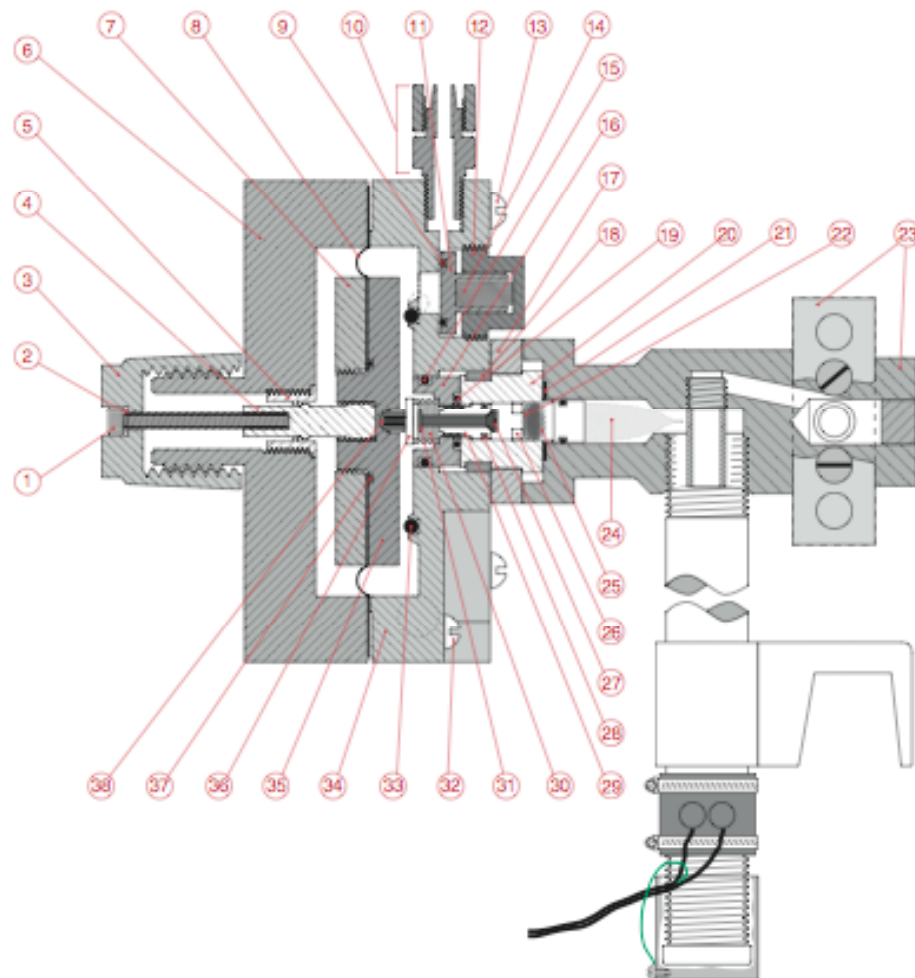

Item No.	Part No.	Description	Qty.	Item No.	Part No.	Description	Qty.
1	BTE-511-500	10-24 x 2" Socket Head Cap Screw	1	25	YRE-455-500	Filter Floss	1
2		Kynar Washer	1	26	YRE-184-500	Filter Stop	1
3	YRE-541-500	Vacuum Reset Knob	1	27	YRE-112-500	Inlet Valve	1
4	YRE-546-500	Guide Pin	1	28	ORE-YIT-011	O-Ring	1
5	YRE-545-500	Collar	1	29	YRE-110-500	Valve Seat	1
6	YRE-555-500	Front Body	1	30	SPE-104-000	Inlet Spring	1
7	YRE-269-500	Diaphragm Front Plate	1	31	YRE-113-500	Spring Holder	1
8	DIE-106-500	Diaphragm	2	32	BTE-STA-124	1/4 - 20 x 1 3/4" Bolt	1
9	ORE-CEM-114	O-Ring (Vent Valve)	1	33	ORE-YIT-332	O-Ring	1
10	TCE-100-100	Vent Tubing Connector (3/8")	1	34	YRE-556-250	Back Body (up to 250 PPD)	1
11	YRE-521-500	Vent Cup	1	34	YRE-556-500	Back Body (500 PPD)	1
12	YRE-522-500	Vent Cap	1	35	YRE-547-500	Diaphragm Back Plate	1
13	BTE-STA-129	1/4 - 20 x 2 1/4" Bolt	4	36	YRE-183-500	Spring Retainer	1
14	SPE-100-100	Vent Spring	1	37	ORE-YIT-028	O-Ring	1
15	ORE-YIT-212	O-Ring	1	38	YRE-111-500	Vent Plug	1
16	YRE-182-500	Seal Plug	1		BTE-STA-125	1/4 - 20 x 2 3/4" Bolt	2
17	YRE-739-500	Ton Back Plate	1		TCE-100-100	3/8" Tubing Connector (100 PPD)	1
18	YRE-142-500	Retainer Clip	1		TCE-106-250	1/2" Tubing Connector (250 PPD)	1
19	ORE-YIT-112	O-Ring	1		TCE-110-500	5/8" Tubing Connector (500 PPD)	1
20	YRE-141-501	Inlet Capsule	1			- Not shown.	
21	GAE-LED-111	Lead Gasket	1	SERIES 9000 VACUUMREGULATOR TON CONTAINER MOUNTED			
22	YRE-101-500	Inlet Screen	1				
23	YRE-738-500	Ton Inlet Assembly with Yoke and Bolts	1				
24	YRE-126-500	Filter	1				
24	YRE-126-500	Filter	1				

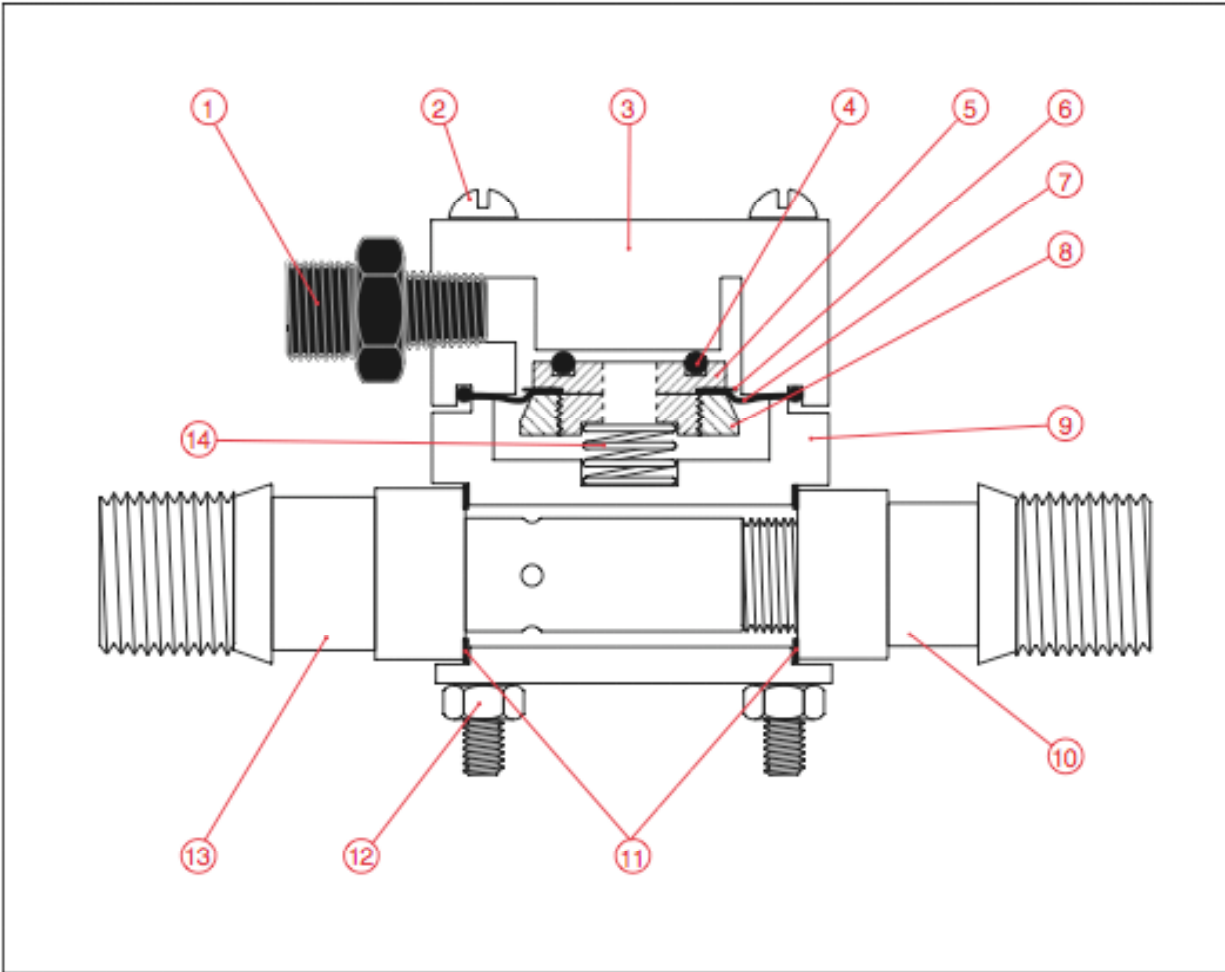

Item No.	Description	Quantity	Part No.
1	3/8" Tubing Connector	1	TCE-100-100
2	5/16 - 18 x 4" Bolt	4	BTE-STA-136
3	Top Body	1	EJE-237-250
4	O-Ring	1	ORE-CEM-210
5	Diaphragm Bolt	1	EJE-236-500
6	Support Diaphragm	1	DIE-105-500
7	Diaphragm	1	DIE-104-500
8	Diaphragm Nut	1	EJE-146-500
9	Bottom Body	1	EJE-153-500
10	Multi Purpose Diffuser	1	EJE-982-100
11	O-Ring	2	ORE-BUN-121
12	5/16 - 18 Nut	4	NTE-STA-104
13	Nozzle	1	see below
14	Spring	1	SPE-106-000

***Note: Available Nozzles:**
 CNE 016-106 (10 ppd max.)
 CNE 013-128 (25 ppd max.)
 CNE 015-156 (50 ppd max.)
 CNE 012-191 (100 ppd max.)

EJECTOR ASSEMBLY : O-RING STYLE
 EJE-100-CL2

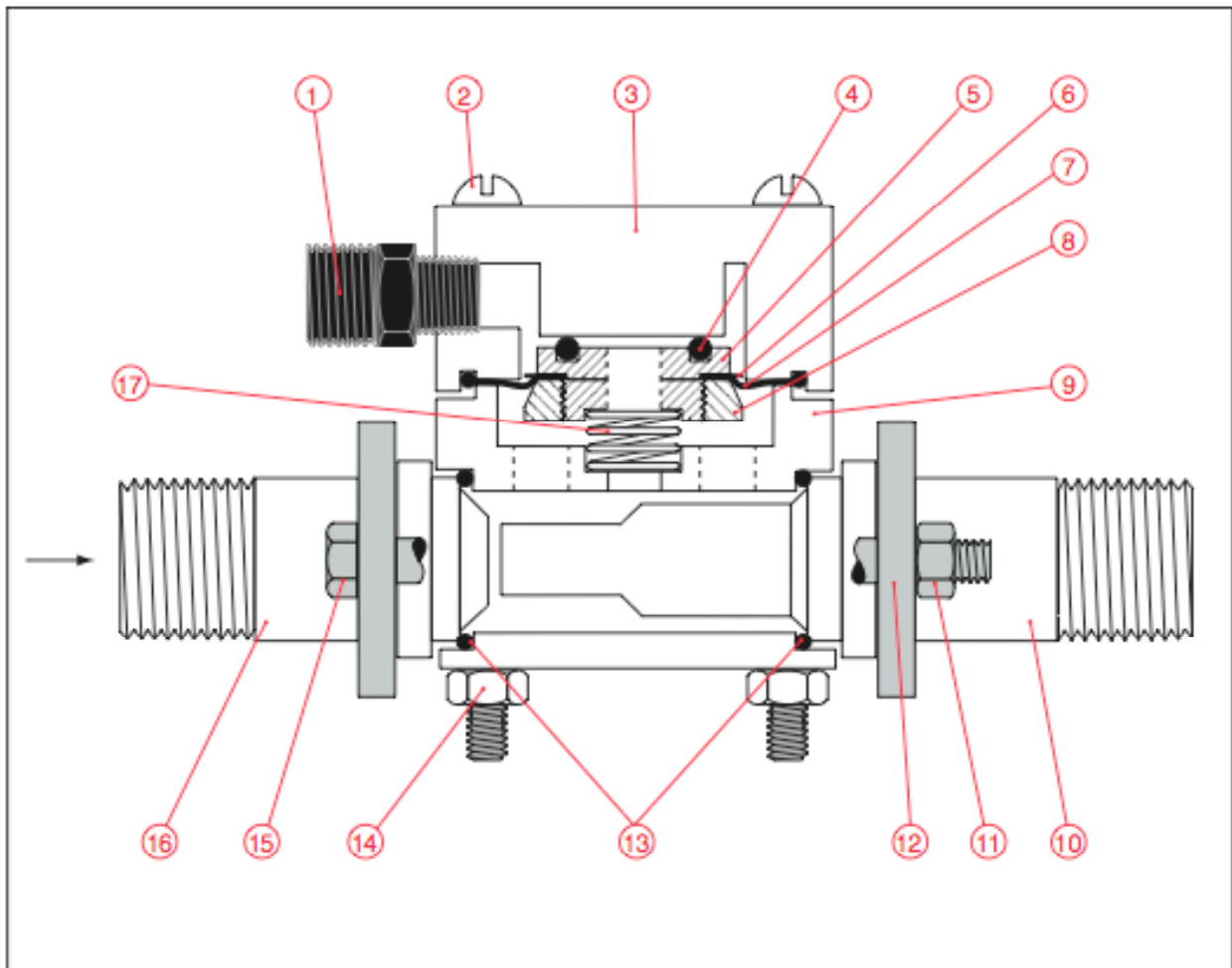

Item No.	Description	Quantity	Part No.
1	1/2" Tubing Connector	1	TCE-106-250
2	5/16 - 18 x 4" Bolt	4	BTE-STA-136
3	Top Body	1	EJE-237-250
4	O-Ring	1	ORE-CEM-210
5	Diaphragm Bolt	1	EJE-236-500
6	Support Diaphragm	1	DIE-105-500
7	Diaphragm	1	DIE-104-500
8	Diaphragm Nut	1	EJE-146-500
9	Bottom Body	1	EJE-153-500
10	Throat	1	• TTE-189-386
11	3/8 - 16 Nut	2	NTE-STA-106
12	Flange	2	EJE-136-500
13	O-Ring	2	ORE-BUN-121
14	5/16 - 18 Nut	4	NTE-STA-104
15	3/8 - 16 x 4 1/2" Bolt	2	BTE-STA-145
16	Nozzle	1	• TNE-187-300
17	Spring	1	SPE-106-000

***Note:** Many different nozzle/throat combinations are available to work within given hydraulic conditions. The above sizes are supplied as standard equipment. Refer to nozzle sizing charts for correct sizing.

EJECTOR ASSEMBLY: O-RING STYLE
EJE-250-CL2

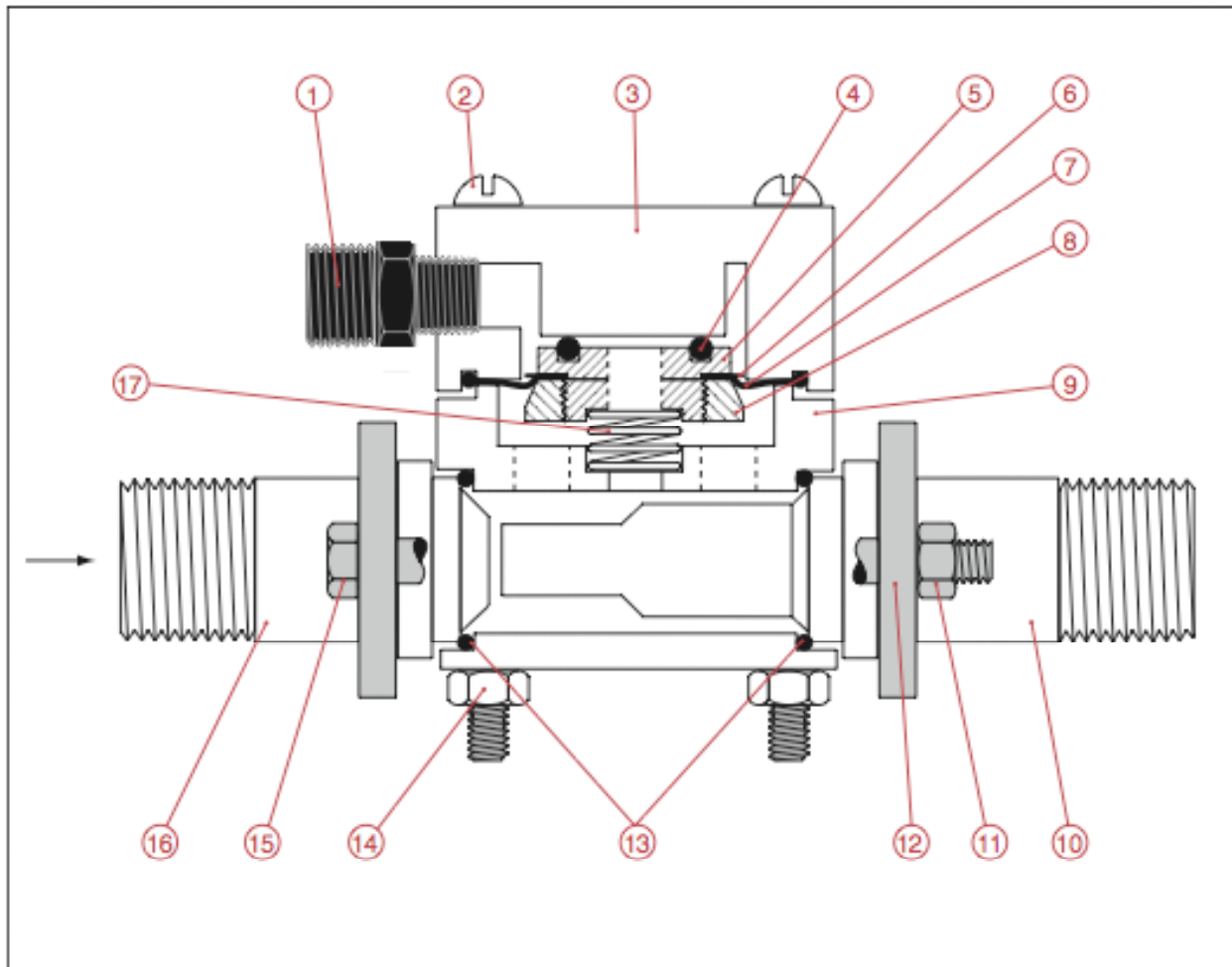

Item No.	Description	Quantity	Part No.
1	5/8" Tubing Connector	1	TCE-110-500
2	5/16 - 18 x 4" Bolt	4	BTE-STA-136
3	Top Body	1	EJE-237-500
4	O-Ring	1	ORE-CEM-210
5	Diaphragm Bolt	1	EJE-236-500
6	Support Diaphragm	1	DIE-105-500
7	Diaphragm	1	DIE-104-500
8	Diaphragm Nut	1	EJE-146-500
9	Bottom Body	1	EJE-153-500
10	Throat	1	• TTE-189-386
11	3/8 - 16 Nut	2	NTE-STA-106
12	Flange	2	EJE-136-500
13	O-Ring	2	ORE-BUN-121
14	5/16 - 18 Nut	4	NTE-STA-104
15	3/8 - 16 x 4 1/2" Bolt	2	BTE-STA-145
16	Nozzle	1	• TNE-187-300
17	Spring	1	SPE-106-000

***Note:** Many different nozzle/throat combinations are available to work within given hydraulic conditions. The above sizes are supplied as standard equipment. Refer to nozzle sizing charts for correct sizing.

EJECTOR ASSEMBLY
EJE-500-CL2

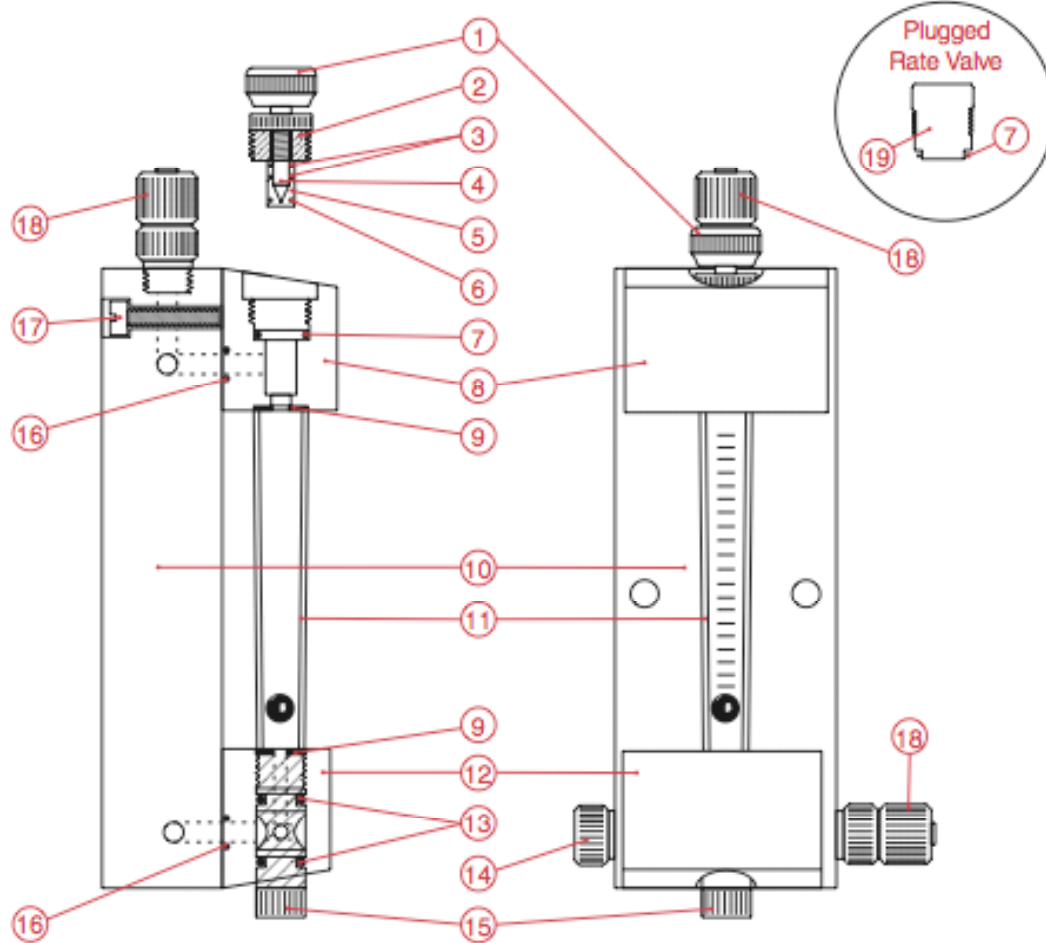

Item No.	Description	Part No.	Item No.	Description	Part No.
1	Rate Valve Assembly, 10 ppd max.	RYE-118-002	11	Meter Tube, 4 ppd max.	MTE-108-004
1	Rate Valve Assembly, 100 ppd max.	RYE-118-003	11	Meter Tube, 10 ppd max.	MTE-108-010
2	Rate Valve Bonnet, 250 ppd max.	RYE-124-200	11	Meter Tube, 25 ppd max.	MTE-108-025
3	O-Ring	ORE-VIT-006	11	Meter Tube, 50 ppd max.	MTE-108-050
4	Rate Valve Plug, 10 ppd max.	RYE-659-002	11	Meter Tube, 100 ppd max.	MTE-108-100
4	Rate Valve Plug, 100 ppd max.	RYE-659-003	12	Bottom Meter Block	MBE-109-100
5	Rate Valve Sleeve, 10 ppd max.	RYE-125-002	13	O-Ring	ORE-VIT-112
5	Rate Valve Sleeve, 100 ppd max.	RYE-125-003	14	1/4" NPT Plug	PLE-108-200
6	O-Ring	ORE-VIT-010	15	Meter Inlet, 10 ppd max.	MIE-219-010
7	O-Ring	ORE-VIT-110	15	Meter Inlet, 250 ppd max.	MIE-140-200
8	Top Meter Block	MBE-110-100	16	O-Ring	ORE-VIT-012
9	Meter Gasket, 10 ppd max.	GAE-VIT-101	17	10-24 x 1" Bolt	BTE-STA-126
9	Meter Gasket, 25 ppd max.	GAE-VIT-102	18	3/8" Tubing Connector	TCE-100-100
9	Meter Gasket, 100 ppd max.	GAE-VIT-103	19	Bonnet Plug, 250 ppd	PLE-175-250
10	Meter Panel Body	MPE-248-200	REMOTE METER PANEL ASSEMBLY: 100PPD RME-100-CL2		

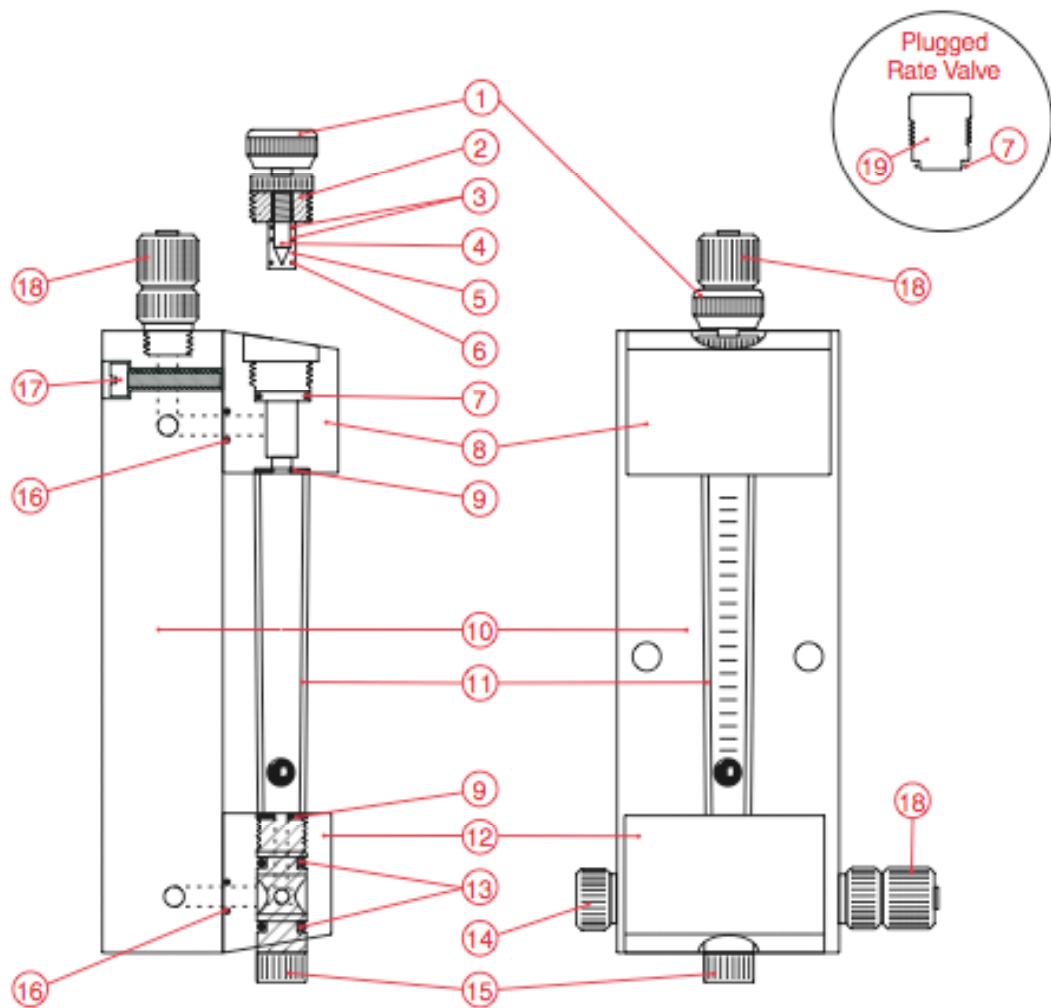

Item No.	Description	Part No.	Item No.	Description	Part No.
1	Rate Valve Assembly, 250 ppd max.	RYE-118-003	11	Meter Tube, 250 ppd max.	MTE-108-250
2	Rate Valve Bonnet, 250 ppd max.	RYE-124-200	12	Bottom Meter Block	MBE-116-200
3	O-Ring	ORE-YIT-006	13	O-Ring	ORE-YIT-112
4	Rate Valve Plug, 250 ppd max.	RYE-659-003	14	1/4" NPT Plug	PLE-108-000
5	Rate Valve Sleeve, 250 ppd max.	RYE-125-003	15	Meter Inlet, 250 ppd max.	MIE-140-200
6	O-Ring	ORE-YIT-010	16	O-Ring	ORE-YIT-012
7	O-Ring	ORE-YIT-110	17	10-24 x 1" Bolt	BTE-STA-126
8	Top Meter Block	MBE-117-200	18	1/2" Tubing Connector	TCE-106-200
9	Meter Gasket, 250 ppd max.	GAE-YIT-104	19	Bonnet Plug, 250 ppd	PLE-175-250
10	Meter Panel Body	MPE-248-200			
			REMOTE METER PANEL ASSEMBLY: 250PPD RME-250-CL2		

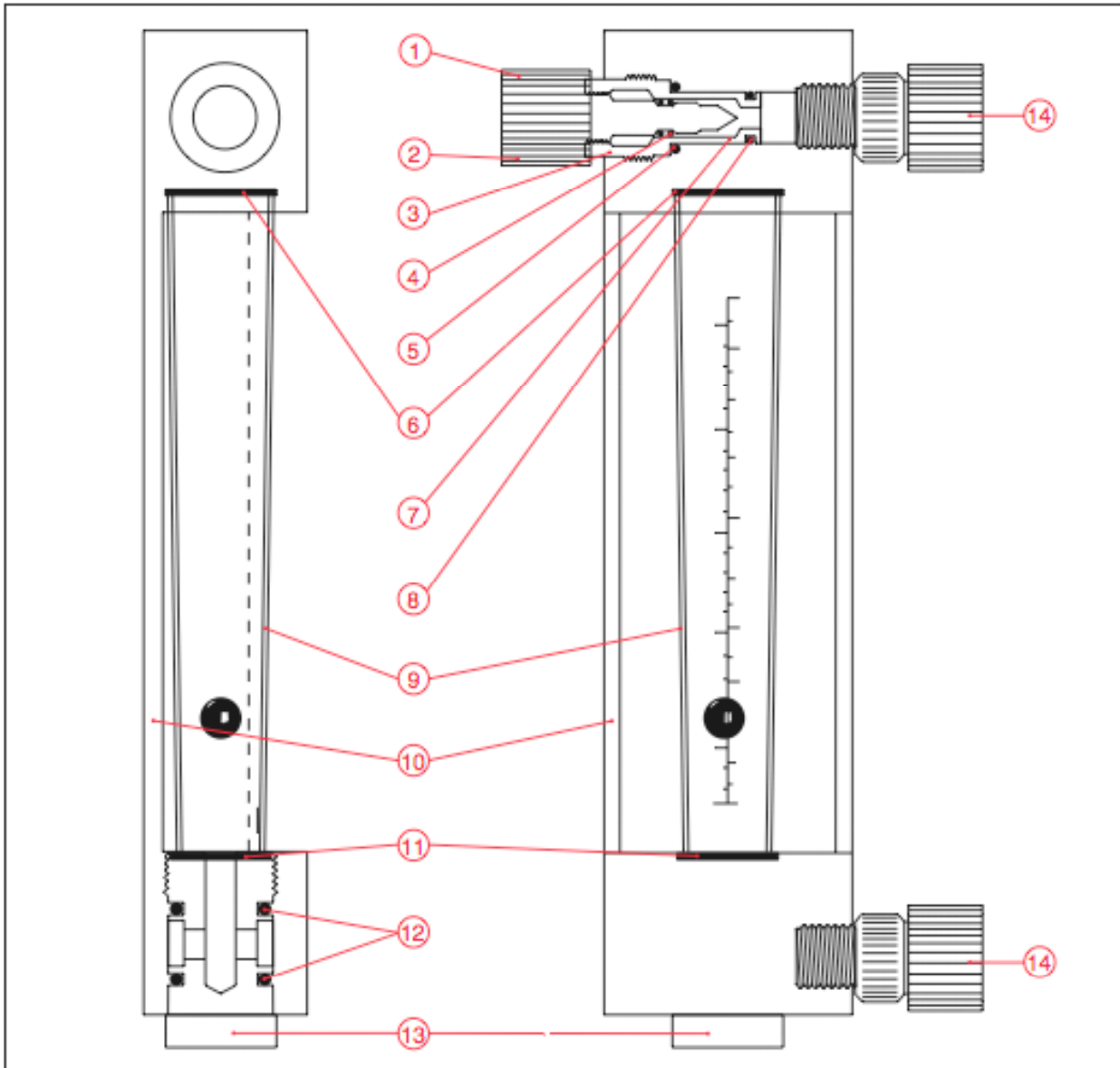

Item No.	Description	Quantity	Part No.	Item No.	Description	Quantity	Part No.
1	Rate Valve Assembly, 500 ppd	1	RYE-118-500	11	Bottom Meter Gasket	1	GAE-YIT-115
2	Rate Valve Plug, 500 ppd	1	RYE-651-500	12	O-Ring	1	ORE-YIT-212
3	Rate Valve Bonnet, 500 ppd	1	RYE-224-500	13	Meter Inlet	1	MIE-232-500
4	O-Ring	1	ORE-YIT-010	14	3/8" Tubing Connector (100 ppd or less)	1	TCE-100-100
5	O-Ring	1	ORE-YIT-112	14	3/8" Tubing Connector (250 & 500 ppd)	1	TCE-110-500
6	Top Meter Gasket	1	GAE-YIT-116	15*	Top Meter Tube Adapter	1	MTE-126-250
7	Rate Valve Sleeve, 500 ppd	1	RYE-116-500	16*	Bottom Meter Tube Adapter	1	MTE-127-250
8	O-Ring	1	ORE-YIT-012	*Not shown. Parts 15 and 16 are used only on tubes of 100 PPD or less.			
9	Meter Tube, 4 ppd	1	MTE-129-004	REMOTE METER PANEL ASSEMBLY: 500 PPD MPE-500-CL2			
9	Meter Tube, 10 ppd	1	MTE-129-010				
9	Meter Tube, 25 ppd	1	MTE-129-025				
9	Meter Tube, 50 ppd	1	MTE-129-050				
9	Meter Tube, 100 ppd	1	MTE-129-100				
9	Meter Tube, 250 ppd	1	MTE-129-250				
9	Meter Tube, 500 ppd	1	MTE-129-500				
10	Meter Panel Body	1	MPE-259-500				

Nozzle Tables

10 PPD (200 gr/hr)

Nozzle >	16		13	
Ejector Backpressure	Standard PSI @ GPM		PSI @ GPM	
0	18	1.5	12	2.5
10	33	1.9	22	3.0
20	48	2.1	35	3.2
30	60	2.3	50	3.5
40	75	2.5	62	3.8
50	90	2.8	76	4.0
60	103	2.9	90	4.3
70	116	3.1	103	4.5
80	130	3.2	120	4.8
90	145	3.4	140	5.1
100	156	3.5	157	5.3
110	171	3.7	170	5.6
120	185	3.8	185	5.8
130	198	3.9	198	6.0
140	213	4.1	213	6.2
150	227	4.3	227	6.4
160	240	4.5	240	6.6

Nozzle Tables

50 PPD (1 Kg/hr)

Nozzle >	15		12		13	
Ejector Backpressure	Standard PSI @ GPM		PSI @ GPM		PSI @ GPM	
0	25	4.0	16	4.0	30	3.2
10	35	4.5	25	5.0	55	3.7
20	50	5.1	35	5.8	75	4.0
30	60	5.4	45	6.3	95	4.4
40	75	6.0	57	7.1	120	4.8
50	95	6.6	75	8.0	141	5.1
60	100	6.8	90	8.6	162	5.4
70	120	7.2	103	9.1	183	5.7
80	134	7.6	114	9.6	205	6.1
90	147	7.8	126	10.0	226	6.3
100	160	8.1	138	10.4	247	6.6
110	173	8.4	150	10.8	268	6.9
120	188	8.7	165	11.3	290	7.3
130	200	9.0	176	11.8	-	-
140	213	9.2	187	12.2	-	-
150	226	9.5	198	12.7	-	-
160	240	9.8	211	13.3	-	-

25 PPD (500 gr/hr)

Nozzle >	13		16	
Ejector Backpressure	Standard PSI @ GPM		PSI @ GPM	
0	25	3.0	40	1.9
10	35	3.2	60	2.2
20	47	3.4	80	2.5
30	60	3.7	100	2.9
40	73	4.0	120	3.2
50	90	4.3	140	3.4
60	100	4.5	160	3.6
70	115	4.7	180	3.8
80	130	4.9	200	4.0
90	143	5.2	220	4.2
100	155	5.3	240	4.4
110	170	5.5	260	4.6
120	185	5.7	280	4.8
130	198	5.9	300	5.1
140	212	6.1	-	-
150	226	6.3	-	-
160	240	6.5	-	-

100 PPD (2 Kg/hr)

Nozzle >	12		15	
Ejector Backpressure	Standard PSI @ GPM		PSI @ GPM	
0	25	5.0	50	5.1
10	50	6.7	60	5.4
20	65	7.3	80	6.1
30	75	8.0	95	6.5
40	89	8.6	110	7.0
50	100	9.0	120	7.2
60	110	9.3	132	7.4
70	125	9.9	150	7.9
80	142	10.5	165	8.3
90	155	11.0	185	8.7
100	170	11.5	200	9.0
110	180	11.9	213	9.3
120	194	12.7	228	9.5
130	208	13.2	244	9.9
140	222	13.7	260	10.2
150	235	14.2	275	10.4
160	250	14.5	291	10.8

Nozzle Tables

250 PPD (5 Kg/hr)

Nozzle >	.300		.250	
Throat >	.386		.386	
Ejector Backpressure	Standard PSI @ GPM		PSI @ GPM	
0	24	11	25	9.0
10	40	13.2	50	11
20	52	15	68	12.5
30	65	16.7	85	14.5
40	77	18.2	100	16
50	87	19.7	112	17
60	100	21	123	18
70	113	22.3	130	19
80	125	23.3	143	19.6
90	137	24.5	155	20.3
100	148	25.4	166	21
110	160	26.3	177	21.6
120	172	27	-	-
130	183	27.8	-	-
140	196	28.7	-	-
150	208	29.4	-	-
160	217	30	-	-

500 PPD (10 Kg/hr)

Nozzle >	.300		.375		.250	
Throat >	.386		.562		.386	
Ejector Backpressure	Standard PSI @ GPM		PSI @ GPM		PSI @ GPM	
0	48	15	20	15	50	10.5
10	72	17.3	35	20.5	90	15
20	88	20.1	50	24	115	17.5
30	105	22	62	27	135	19
40	123	24	80	31	150	20
50	140	26	96	34	170	21
60	160	26.7	111	37	-	-
70	175	27.3	130	41	-	-
80	192	28.5	145	44	-	-
90	210	29.2	-	-	-	-